

The TIMBERMASTER with 6 working shafts

Profiles can be applied to the workpiece using the fifth bottom and the sixth top working shafts, or they can be used as a multi-blade saw for separating or scoring. You can, for example, manufacture rounded profiles for block house construction with a machine fitted out in this way. In addition, all other profile types can be rationally produced using this machine and matching your production requirements.

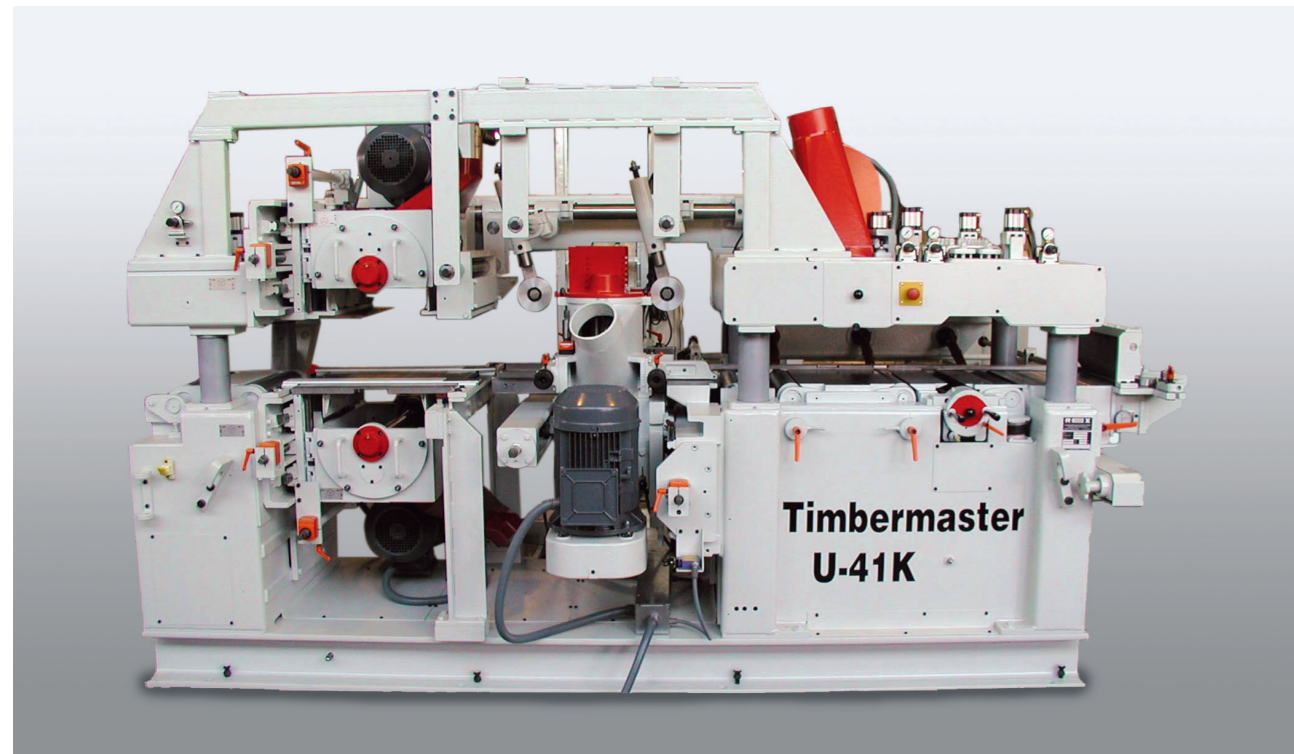

Sawing widths

A wide range of workpiece widths can be continually processed using the EMA system. The scanned width dimensions are transmitted to the vertical spindles which automatically set themselves to the new dimension. If the width scanning system is switched off, it is of course possible to continue planing normally.

The TIMBERMASTER from REX

- universal in use
- indestructible stability
- a huge advantage for your production

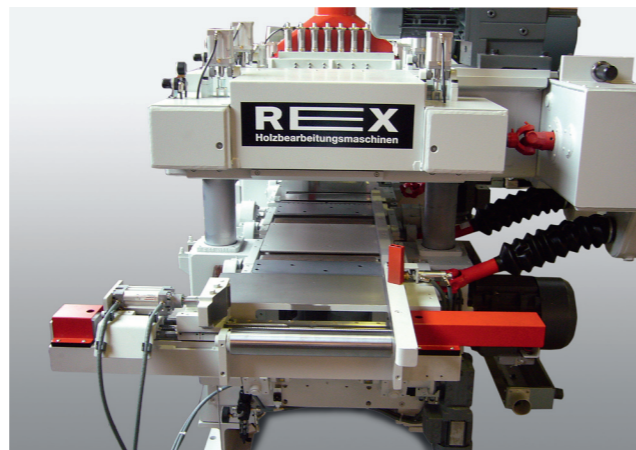

TIMBERMASTER
The Powerhouse from REX

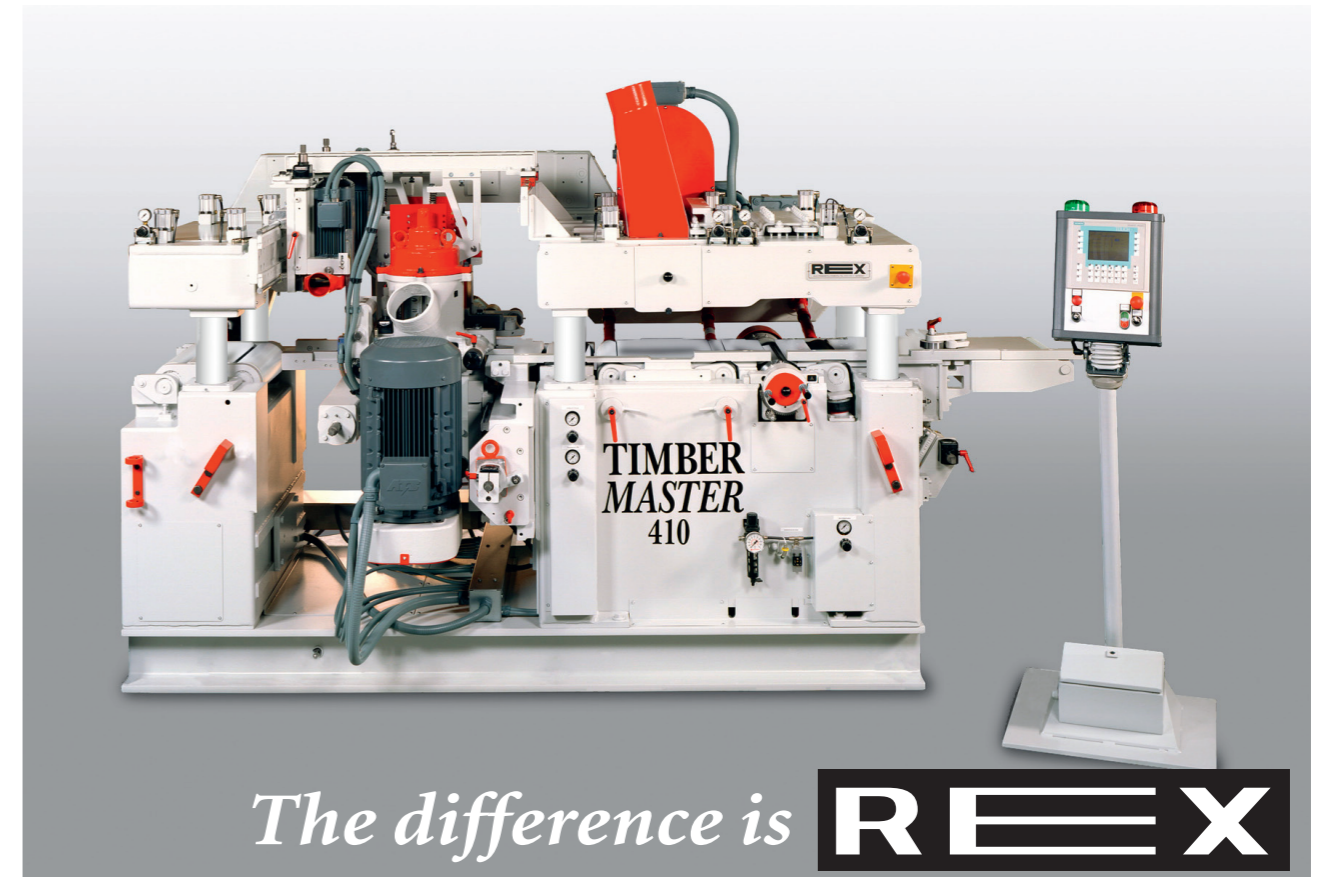

The difference is **REX**

With the **TIMBERMASTER**, REX can also offer your company the facility for rational production of planed goods on the basis of the most modern technology available. Because: the price to performance ratio is exactly right!!

The **TIMBERMASTER** is the perfect compact planing machine with between 4 and in world 10 working shafts, which makes it effectively usable for any work. The complete technical fittings make this machine an absolute „powerhouse“.

- heavy-duty planing shaft or planing head version
- heavy solid feed system
- working widths up to 630 mm
- electronic height and width positioning controlle
- vertical shafts can be used floating
- chamfering units for chamfering on all sides
- chamfering units can be used floating

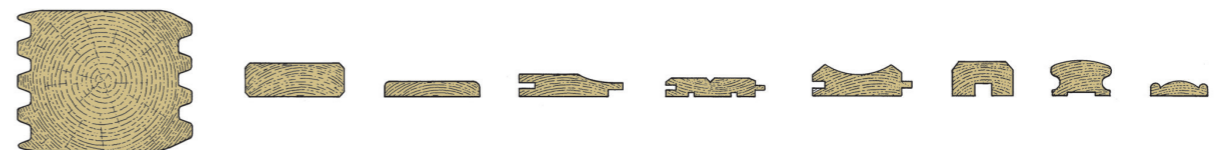



REX safety cabins

CE conformity is guaranteed by a **REX** safety, dust and noise protection cabin. Our cabins are fitted out so that the machines are completely accessible at both the operating and rear side when the cabin is open. This means that maintenance and service work is easy to carry out. You can choose any door orientation or size.

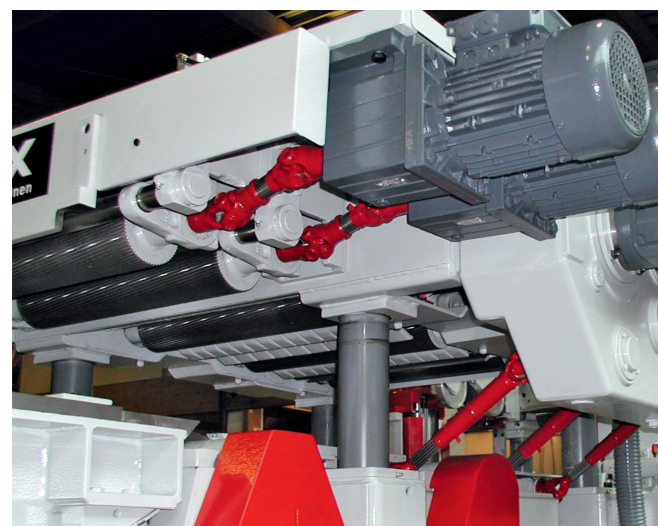

A powerful feed system

The only way to transport heavy, wet, frozen or even small, thin and narrow workpieces perfectly through the machine is using a perfect feed system.

All **TIMBERMASTER** feed rollers are full machine working width and mounted on both sides. This means that the workpiece is guided by the rollers across its entire width, which guarantees problem-free workpiece transport.

Conventional narrow machines are only fitted with feed rollers mounted on one side which cannot guarantee problem-free workpiece transport.

This cannot happen with the **TIMBERMASTER**. The standard package includes **10 feed rollers mounted on both sides driven by heavy-duty cardan shafts.**



The TIMBERMASTER with 5 working shafts and chamfering units

Profiles can be applied to the workpiece using the fifth bottom working shaft, or they can be used as a multi-blade saw for separating or scoring. These additional working shafts can, of course, be supplied as a shaft working from above.

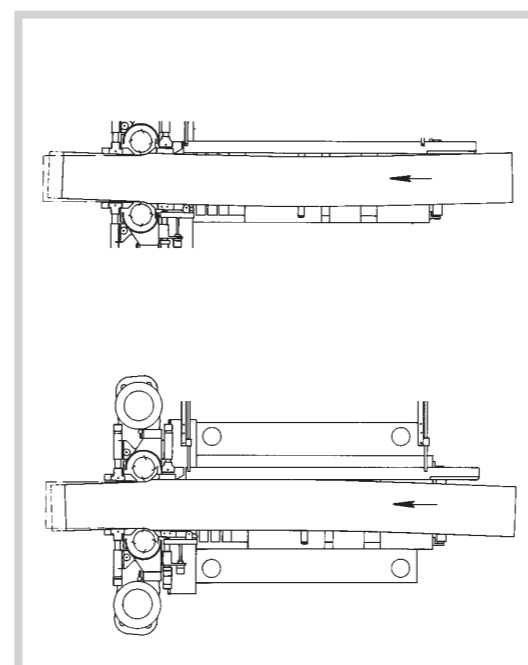
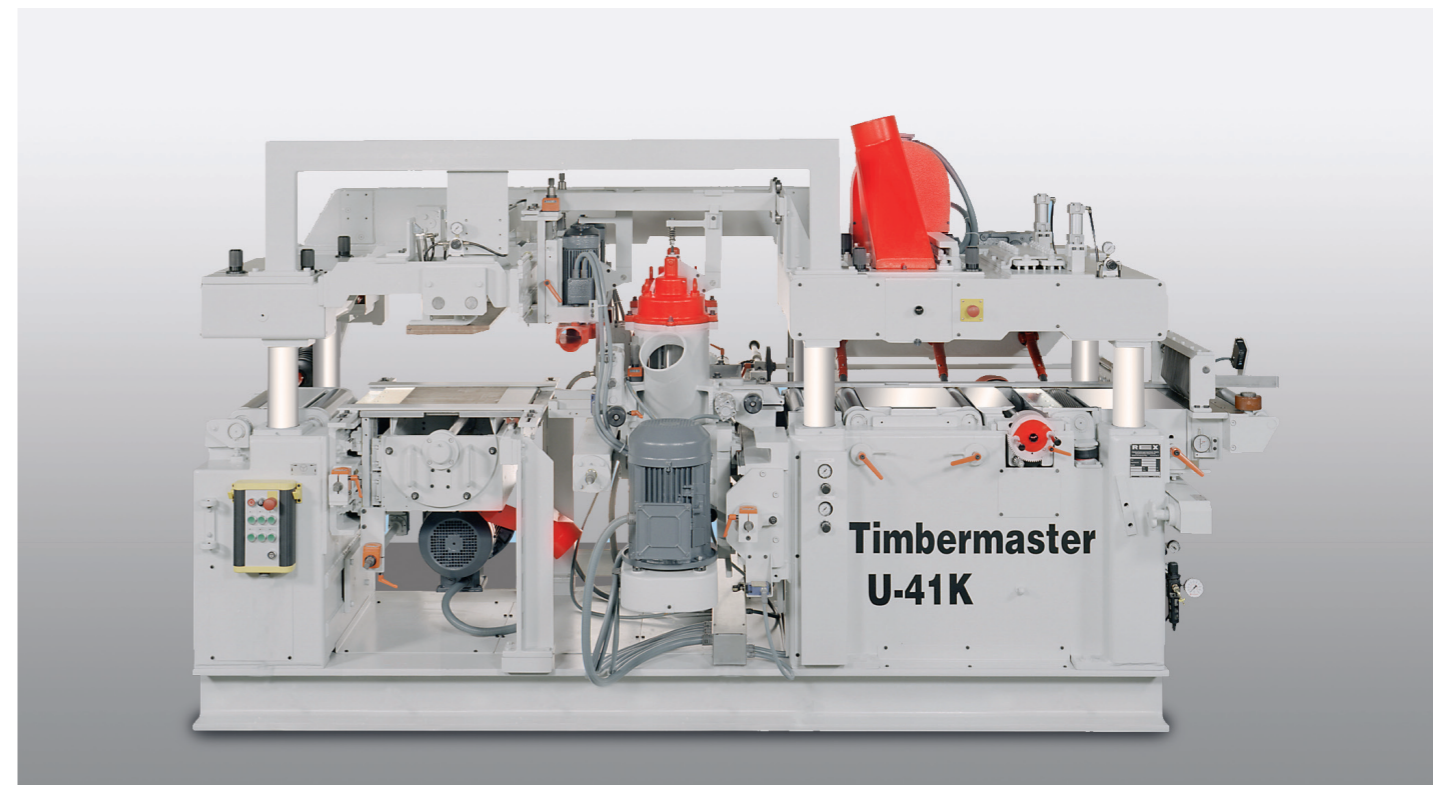

The REX PSV system (floating vertical shafts)

The **PSV system (floating vertical shafts)** developed by **REX** makes it possible for the vertical shafts to float parallel within a range of around 30 mm in the standard version. The workpiece is pneumatically centred and the vertical shafts follow the workpiece curves whilst retaining the width. The result is a completely smoothly-planed workpiece with the absolute minimum in material loss. The **REX PSV system** can be switched over to normal mode using a lever on the machine operator side.

The REX AFV system (chamfering system)

You can use this system to automatically chamfer your workpiece on all sides during planing or to provide rounded profiles. You can plane any workpiece dimension with chamfers or round profiles without extra retooling time and without switching the motor off.